



Simulations of hybrid system varying solar radiation and microturbine response time

Yolanda Fernández Ribaya, Eduardo Álvarez, José Pablo Paredes Sánchez, and Jorge Xiberta Bernat

Citation: *AIP Advances* **5**, 077110 (2015); doi: 10.1063/1.4926436

View online: <http://dx.doi.org/10.1063/1.4926436>

View Table of Contents: <http://scitation.aip.org/content/aip/journal/adva/5/7?ver=pdfcov>

Published by the *AIP Publishing*

Articles you may be interested in

[Optimization of angle of inclination of the hybrid photovoltaic-thermal solar collector using particle swarm optimization algorithm](#)

J. Renewable Sustainable Energy **6**, 053116 (2014); 10.1063/1.4896956

[Simulation of a new grid-connected hybrid generation system with Stirling engine and wind turbine](#)

J. Renewable Sustainable Energy **5**, 063128 (2013); 10.1063/1.4850475

[Fuzzy logic controller based power management for a standalone solar/wind/fuel cell fed hybrid system](#)

J. Renewable Sustainable Energy **5**, 053147 (2013); 10.1063/1.4827315

[Case study: Simulation and optimization of photovoltaic-wind-battery hybrid energy system in Taleghan-Iran using homer software](#)

J. Renewable Sustainable Energy **4**, 053111 (2012); 10.1063/1.4754440

[Energy and exergy analysis of hybrid photovoltaic/thermal solar water heater considering with and without withdrawal from tank](#)

J. Renewable Sustainable Energy **2**, 043106 (2010); 10.1063/1.3464754



Simulations of hybrid system varying solar radiation and microturbine response time

Yolanda Fernández Ribaya,^a Eduardo Álvarez,
José Pablo Paredes Sánchez, and Jorge Xiberta Bernat
*Department of Energy E.I.M.E.M., University of Oviedo. 13 Independencia Street 2nd floor,
36004, Oviedo, Spain*

(Received 16 April 2015; accepted 25 June 2015; published online 6 July 2015)

Hybrid power systems, such as combinations of renewable power sources with intermittent power production and non-renewable power sources, theoretically increase the reliability and thus integration of renewable sources in the electrical system. However, a recent increase in the number of hybrid installations has sparked interest in the effects of their connection to the grid, especially in remote areas. This paper analyses a photovoltaic-gas microturbine hybrid system dimensioned to be installed in La Paz (Mexico). The research presented in this paper studies and quantifies the effects on the total electric power produced, varying both the solar radiation and the gas microturbine response time. The gas microturbine and the photovoltaic panels are modelled using Matlab/Simulink software, obtaining a platform where different tests to simulate real conditions have been executed. They consist of diverse ramps of irradiance that replicate solar radiation variations, and different microturbine response times reproduced by the time constants of a first order transfer function that models the microturbine dynamic response. The results obtained show that when radiation varies quickly it does not produce significant differences in the power guarantee or the microturbine gas consumption, to any microturbine response time. However, these two parameters are highly variable with smooth radiance variations. The maximum total power variation decreases greatly as the radiation variation gets lower. In addition, by decreasing the microturbine response time, it is possible to appreciably increase the power guarantee although the maximum power variation and gas consumption increase. Only in cases of low radiation variation is there no appreciable difference in the maximum power variation obtained by the different turbine response times. © 2015 Author(s). All article content, except where otherwise noted, is licensed under a Creative Commons Attribution 3.0 Unported License. [<http://dx.doi.org/10.1063/1.4926436>]

I. INTRODUCTION

The current world dependency on fossil energy resources brings increasing concern about energy supply security and environmental issues. The only sustainable solutions involve renewable energy and the application of energy efficient technologies.

Solar energy is a renewable resource; it is one of the sustainable and abundantly available energies on the Earth's surface. There are a lot of technologies to exploit solar radiation and photovoltaic (PV) is now commercially available at a decreasing price.¹ Solar panels transform solar energy directly into electricity using semiconductors. One of the major advantages of PV technology is its long lifecycle, with low operation and maintenance costs, due to the fact that it has a minimal number of moving parts. Furthermore, this technology is a clean and environmentally-friendly energy source.²⁻⁴

Energy production by PV systems varies slowly because of day-night cycles and seasonal changes, and quickly because of weather conditions (e.g. passing clouds). The intermittent nature

^aAuthor to whom correspondence should be addressed. Electronic mail: fernandezryolanda@uniovi.es



of solar resources may cause problems of power quality.^{5,6} To reduce these difficulties, and to guarantee electric supply, a hybrid system can be integrated. Hybrid systems are defined as systems that use more than one energy source to supply a certain load.⁷⁻⁹

Adopting hybrid systems to provide electricity for different applications has been widely studied in previous research works.^{10,11} Hybrid systems include two or more energy sources, combining the strengths and weaknesses of each one to supply a stable load. Hybrid systems which include PV panels are widely used to supply different types of loads. The low cost of energy production and the ability to meet energy demand in diverse climatic conditions are the characteristics that distinguish hybrid systems from single resource systems.¹²⁻¹⁴

The design and analysis of PV hybrid systems requires tools that can predict solar resource behaviour under different climatic conditions. The behaviour of PV panels in adverse weather conditions can be characterized using different simulation models.^{15,16}

Integrating renewable energy sources with a backup source, such as a gas microturbine (GMT), makes it possible generate electricity with more reliability under different operational conditions. The use of these microturbines is currently attracting much interest in the distributed generation market and can be considered one of the main resources in this field.¹⁷ GMT offers a lot of advantages over the reciprocating engines of other technologies.¹⁸ These advantages include longer life, lighter weight, smaller size, fewer moving parts, faster response, greater efficiency, lower emissions, lower electricity costs, less noise and more flexible ways to utilize waste fuels.

The increase of renewable penetration in new and emergent energy markets with their need for a sustainable and reliable supply; foment the use of hybrid installations based on combinations of renewable and non-renewable generators. However, the electrical companies in charge of managing the electrical systems of these countries consider it necessary to control the characteristics of the power that is injected into the grid. This issue has a special interest in remote areas, in which intermittent condition of renewable energy may cause grid instabilities. Before the construction of a new renewable or hybrid installation, electrical companies normally require the engineering company in charge of the project to supply them with information about the total power characteristics, establishing limits on aspects such as maximum variations and/or power guarantee.

This research paper studies the influence of the variables GMT response time and solar radiation on the performance of a hybrid PV-GMT installation projected for the area of La Paz in Baja California Sur (Mexico). For this purpose, three parameters: power guarantee, gas consumption and maximum total power variation, obtained in different tests, are evaluated. The Matlab/Simulink tool was used to model the system and to simulate the electric power generation under solar radiation and microturbine response time variations.

The variations of the solar radiations were applied to the model in diverse ramps shaped irradiance signals, while different GMT response times were simulated by the time constant of a GMT based on a first-order transfer function.

The novelty of our work is to show the influence of the GMT response time and solar radiation on the power guarantee, power fluctuations and gas consumption of a modelled hybrid PV-GMT installation.

II. STATE OF THE ART

Hybrid systems that combine renewable and non-renewable resources as auxiliary systems have been the focus of a large number of studies.

Several works have analyzed hybrid PV-Diesel systems. Dufo and Bernal¹⁹ optimized power equipment for a PV-Diesel system using the HOGA program (Hybrid optimization by genetic algorithms) and compared it with a stand-alone PV-only system dimensioned using the classic design method. Their results showed the economic advantages of the PV hybrid system. Nafeh²⁰ sized a hybrid PV-diesel generator with the objective of meeting a given characteristic load for almost an availability of 100%. Sadeghi y Ameri²¹ presented a multi-objective optimization method for calculating the optimum configurations of photovoltaic-battery systems with high reliability and minimum cost for different tilt angles of the panels. Dufo and Bernal²² used a multi-objective evolutionary algorithm to design a PV-Wind-Diesel system and propose a genetic algorithm to develop

a control strategy to minimize running costs. However, in these studies the highly intermittent character of the power supply of PV generators is not taken into account.

Recently, GMT has been considered as an auxiliary system in hybrid combinations. Degobert *et al.*²³ studied the possibility of using photovoltaic systems combined with a high speed micro-turbine and verified its effectiveness in simulation tests. However, the effects of changing MGT response time with different solar radiation scenarios have not been studied.

The study presented quantifies the effects and influence of solar radiation and GMT response time on the electrical power generation and fuel consumption of a hybrid PV-GMT system.

III. HYBRID SYSTEM DESCRIPTION AND MODELLING

The hybrid system has been dimensioned using available climate²⁴ and geography data of the municipality of La Paz, in Baja California Sur, Mexico.

The hybrid system will consist of a 1.2 MW photovoltaic installation combined with a 1 MW GMT generator as a support system (Fig. 1). Electricity produced will be directly exported to the distribution grid.^{25,26}

Two mathematical models for PV and GMT generators have been defined and implemented using Matlab/Simulink. Then, all the components are analyzed jointly to evaluate the performance of the hybrid system.

A. Solar system model

Solar information^{27–29} has been used for the plant design in order to determine the number and type of PV panels as well as their direction and inclination to maximize the capture of solar radiation.^{30,31}

For technical reasons, the 1.2 MW plant will be divided into 12 sub-installations of 100 kW. Each sub-installation will include 330 polycrystalline solar panels of 305 Wp divided into groups of 22 parallel branches with 15 panels in series. Solar panels are inclined at 26° and oriented to the south (azimuth angle $\gamma=0$). The energy generated by each sub-installation will be adapted to the AC grid using a 100kW power inverter.

The plant is projected to have a total of 3,960 PV panels (330x12) and therefore a total peak power of 1.2078 MWp (3,960x305·10⁶).

To define the Matlab/Simulink model, different equations to obtain electrical power from the solar radiation were used.

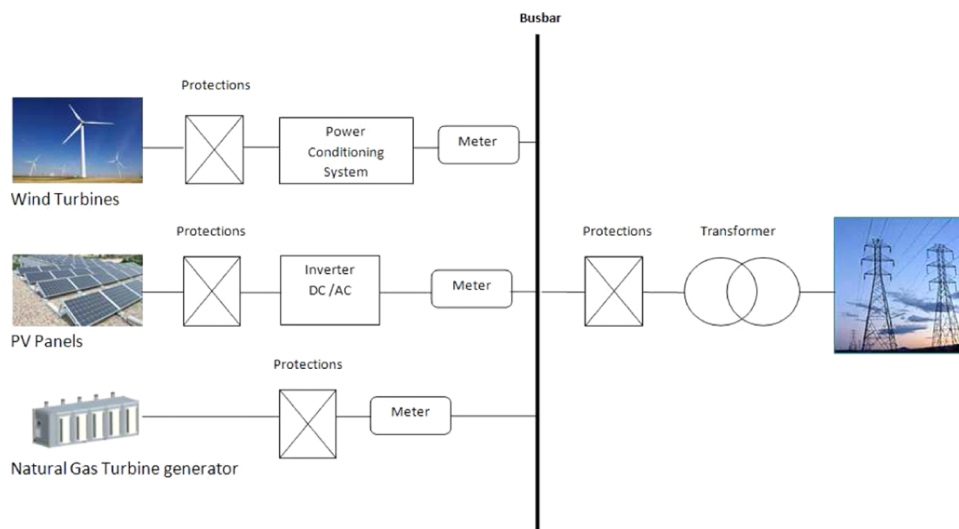

FIG. 1. Hybrid system single line electric diagram.

The input energy of model is the solar radiation. It is estimated on an inclined surface by Equation (1),

$$G_{dm}(\gamma, \beta) = R(\beta) \times G_{dm}(0) \quad (1)$$

where,

- $G_{dm}(\gamma, \beta)$ (Wm^{-2}), is the value of solar radiation of an inclined surface. β is the inclination angle and γ is the azimuth angle
- $G_{dm}(0)$ (Wm^{-2}), is the value of solar radiation on a horizontal surface (kWm^{-2}).
- $R(\beta)$, is the gain factor.

In this specific case, as the PV installation faces south, $\gamma = 0$. R and β have been calculated using the Liu and Jordan³² and Duffie and Beckman methods;³³ their values are $R=1.05$ and $\beta=26^\circ$ respectively.

Using Equation (1) and $G_{dm}(0)$ data of the zone,²⁴ it is possible to calculate the maximum value of solar radiation, which is 1.16 Wm^{-2} .

To determine the photovoltaic power generation, Equation (2) has been used,

$$P_{PV} = P_{max} \times G_{dm}(\gamma, \beta) / G^* \quad (2)$$

where,

- P_{PV} , (W), is the total power produced by the PV plant.
- P_{max} , (Wp), is the total peak power of the PV plant.
- $G_{dm}(\gamma, \beta)$, (Wm^{-2}), is the value of solar radiation of an inclined surface
- PR , (%) is the value of the performance ratio of the PV installation.
- G^* , is the reference radiation, 1 kWm^{-2} .

In this case $P_{max} = 1.2078 \cdot 10^6 \text{ Wp}$ and PR is 82.47% ³¹

Fig. 2 shows the PV model designed. It consists of a “Solar radiation” generator, to define the different possibilities of radiation inputs, introducing the data of different solar radiation ramps that vary from 0 to its maximum value (1.16 Wm^{-2}) in different time intervals (5, 10, 15, 20, 25 and 30 minutes), and “Solar power” module where equations to obtain solar power from the radiation input are implemented.

The “Radiation-Time” and “Solar power- Time” scopes allow us to obtain information about the radiation and the solar power generation in the simulation time (1 hour). The display “kWh solar” allows us to obtain the kWh generated.

B. Gas microturbine model

For this application, a Capstone Microturbine Generator, Model C1000 is used. It is a 1 MW electrical nominal power GMT with about 33% electrical efficiency (at nominal power).

The GMT generator is modelled as a dynamic model taking into account its response time. The response time is the transition time between the fuel input in the combustion chamber and the output of power. The model implemented in Matlab/Simulink software consists of a first order transfer function “MGT time constant” where response time is equivalent to its time constant. Modifying the

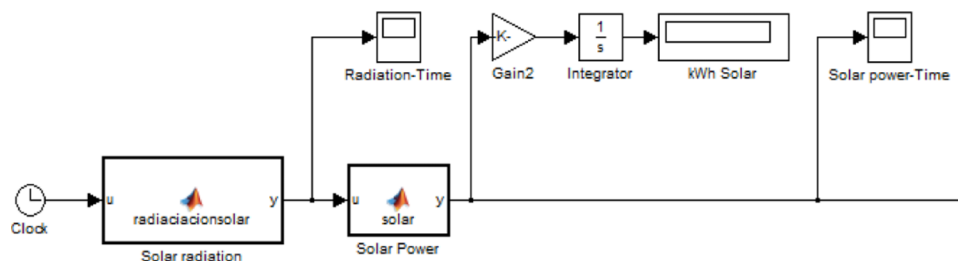

FIG. 2. Solar system model.

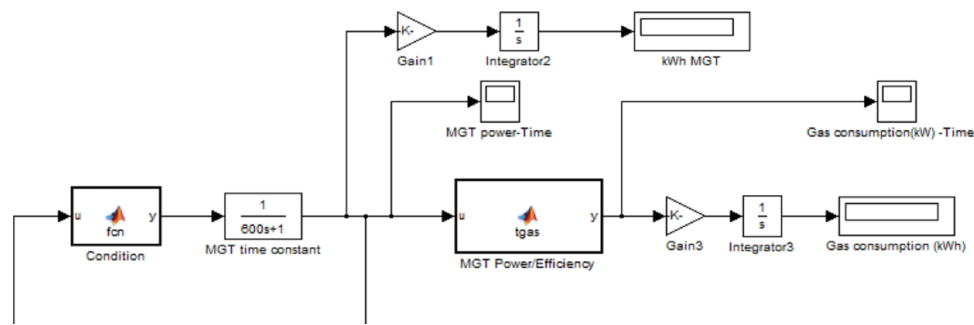

FIG. 3. GMT model.

variable parameter of the transfer function in the model from 120 to 1500 seconds it is possible to simulate the different MGT time constants (2, 4, 6, 8, 12, 14, 16 and 18 minutes).

The GMT model also calculates fuel consumption with the function “MGT Power/Efficiency” using Equation (3):

$$G = P_{GMT}/\eta_{PGMT} \quad (3)$$

where,

- G , (W) is the GMT natural gas consumption.
- P_{GMT} , (W) is the GMT electrical power production.
- η_{PGMT} , (%) is the GMT electrical efficiency, which varies with the value of the electrical power production

Fig. 3 shows the GMT model designed including: a first order transfer function module and the MGT Power/Efficiency module that calculates gas consumption from the electrical power obtained.

The “MGT power-Time” and “Gas consumption (kW) - Time” scopes allow us to obtain information about the power generated and the gas consumption (kW) in the simulation time (1 hour). The displays “kWh MGT” and “Gas consumption (kWh)” allow us to obtain the kWh generated and the gas consumption (kWh).

IV. TEST METHODOLOGY

For the different tests a complete Matlab/Simulink simulation platform has been defined (Fig. 4). It consists of the PV and GMT models and the necessary adaptations so that the GMT generates electricity when PV production is less than 1 MW.

The test methodology consists at first of a simulation test of the platform using a base case with predefined radiation signal and GMT model time constant (or response time); followed by a sensitivity analysis varying both radiation and GMT response time.

In all tests the results include the parameters:

- Power guarantee, (%) defined as the percentage of the test time in which the electrical power is over a fixed power value. In this case this value has been set to 0.9 MW.
- Maximum total power variation (kW/min), defined as the maximum variation of the total hybrid electrical power versus time.
- GMT natural gas consumption during the test (kWh).

A. Base case test definition

The base case is defined by the following data:

- Turbine time constant: 10 minutes³⁴
- G_{dm} (α , β) signal varies in 15-minute ramps from 0 to 100 % and 100% to 0 (Fig. 5). (maximum value in the project location)
- Simulation time: 60 minutes.

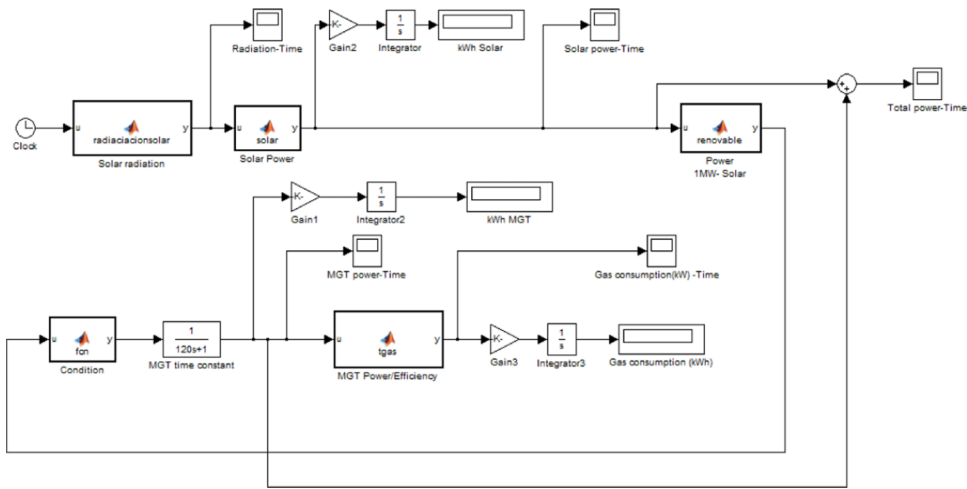

FIG. 4. Simulation platform.

V. RESULTS AND DISCUSSION

In this section results obtained in the base case test and sensitivity analysis tests are presented and discussed.

A. Base case simulation results

For the base case, Fig. 6 shows the power produced by the PV installation (P_{PV}), the microturbine (P_{GMT}) and the fluctuating total power (P_{TOTAL}) obtained.

In this specific case, the generation power was over the power guarantee (0.9 MW) for only 54.23% of the simulation time (1 hour). The GMT consumed 1,158 kWh (of natural gas) and the maximum total power variation obtained was 2.28 kW/min.

B. Sensitivity analysis

Two different sets of 1-hour sensitivity tests were performed, varying first the radiation ramp duration (ramp duration sensitivity analysis), and then the same parameter and the GMT model time

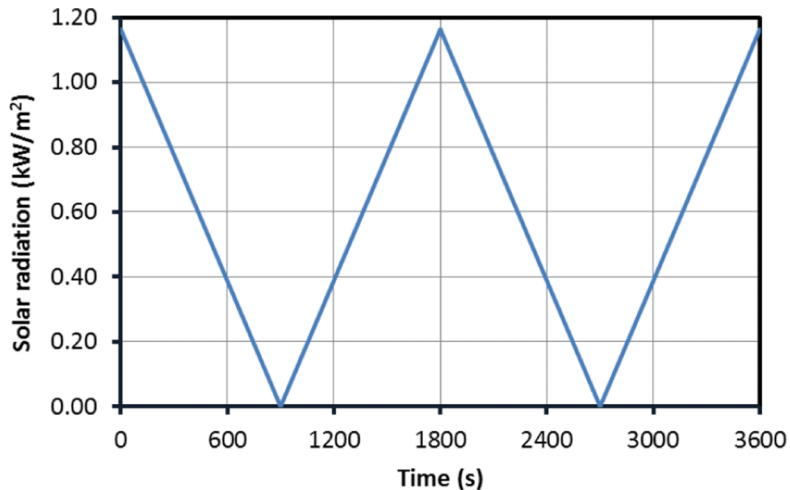

FIG. 5. Solar radiation signal (base case).

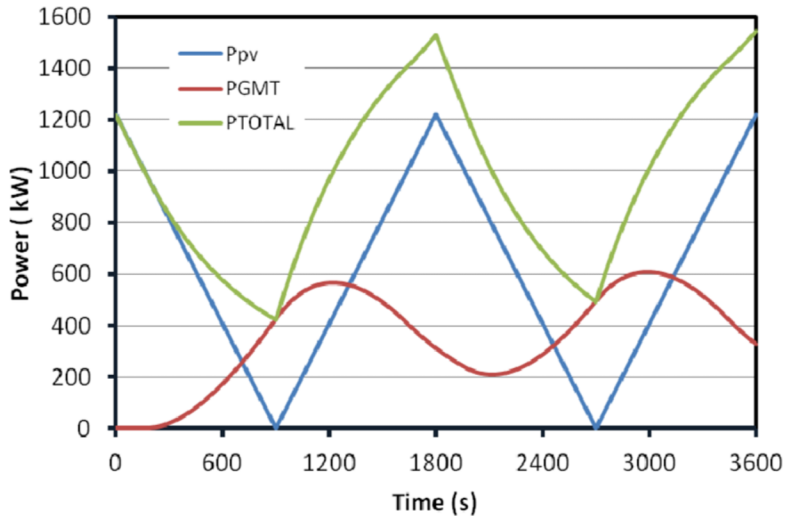

FIG. 6. Electrical power signals (Base case).

constant (ramp duration and GMT model time constant sensitivity analysis). The variations applied to these variables were:

- Radiation ramp duration (from 0 to 100% of the maximum radiation value): 5, 10, 15, 20, 25 and 30 minutes.
- GMT model time constants of: 2, 4, 6, 8, 12, 14, 16 and 18 minutes.

1. Radiation ramp duration sensitivity analysis

Fig. 7 shows values of power guarantee obtained for different solar radiation ramp durations for a GMT model time constant of 10 minutes. The guarantees obtained were around 50-60% of the simulation time. For ramps of 15 minutes or lower, the guarantee remains constant. However, for ramp durations from 20 to 30 minutes, the guarantee values obtained are more varied obtaining the maximum value (60%) for 25 minutes.

Maximum total power variations were sharply reduced as the ramp duration increased. In Fig. 8, it can be seen that a value of 5.3 kW/min was obtained for a 5-minute time ramp, while it dropped to 1.2 kW/min (around 78% reduction) with a ramp of 30 minutes.

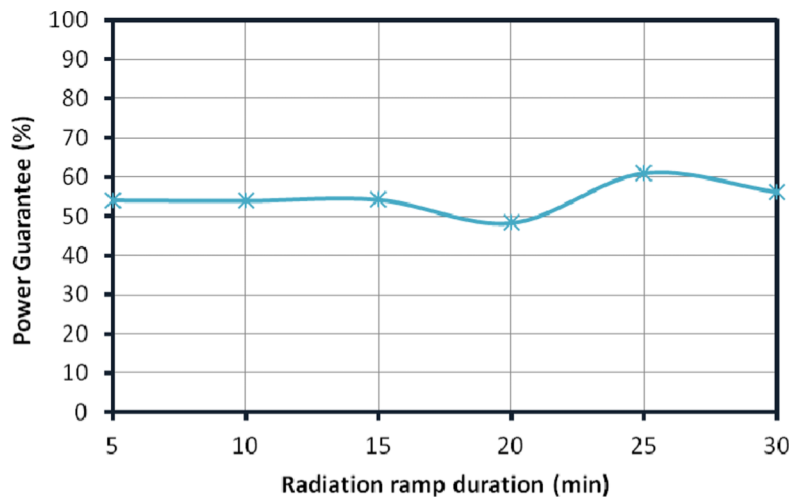

FIG. 7. Power Guarantee (Radiation ramp duration sensitivity analysis).

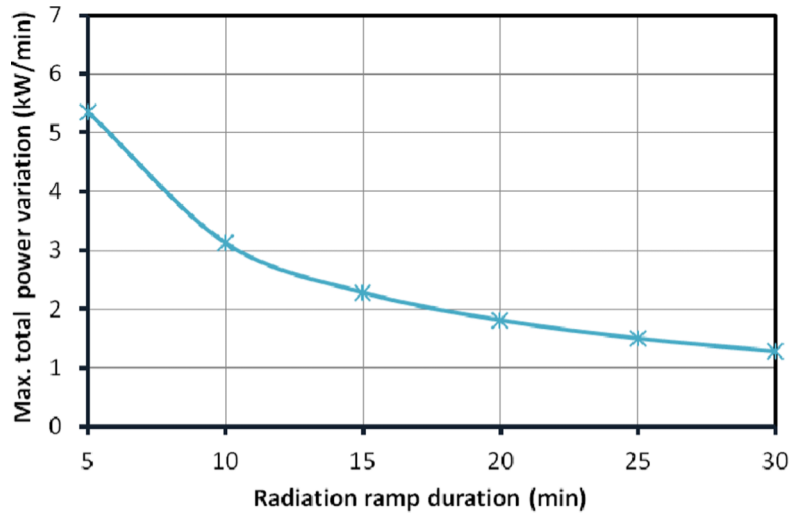

FIG. 8. Maximum total power variation (Radiation ramp duration sensitivity analysis).

Gas consumption slightly increases with ramp duration for ramps of 15 minutes or lower (Fig. 9). Nevertheless, significant variations were obtained with ramp durations of 20, (minimum consumption), 25 and 30 minutes (maximum consumption).

2. Radiation ramp duration and GMT model time constant sensitivity analysis

Fig. 10 shows the results obtained for power guarantee corresponding to different ramp durations. These results show that the tendency is the same for different GMT model time constants. For ramp times between 5 and 20 minutes, the guarantees increase with the reduction in the GMT model time constants (or increase in the GMT response times) following an approximately linear law: 0.8 % per 2 minutes of reduction.

Maximum total power variations (Fig. 11) have the same tendency for each time constant value. Additionally, the variations increase as the GMT model time constants are reduced (or response times are increased). These differences are more appreciable as the ramp duration decreases; eg. for a ramp time of 5 minutes, the maximum variation increases from 4.8 kW/min to 7.4 kW/min (more than 150%) while reducing the time constant from 18 to 2. However, there are no appreciable differences in the maximum total power variation for the time constants for ramps of 25 or 30 min.

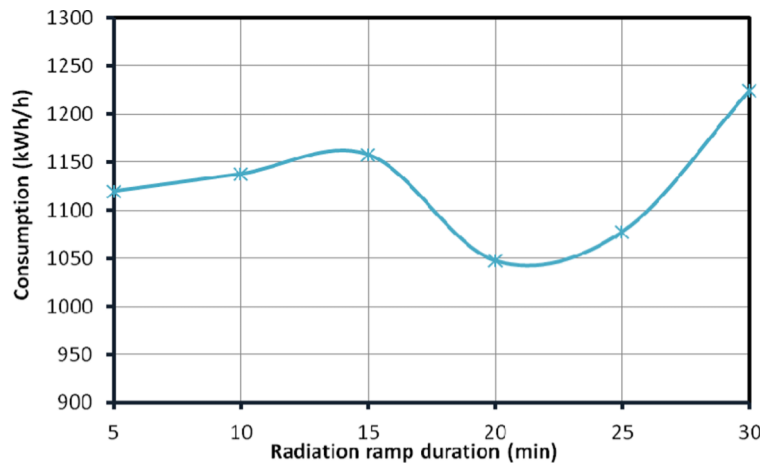

FIG. 9. GMT Gas consumption (Radiation ramp duration sensitivity analysis).

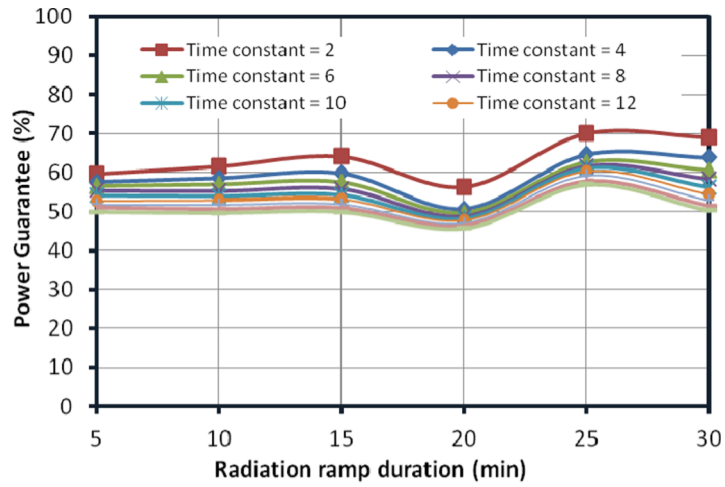

FIG. 10. Power Guarantee (Radiation ramp duration and GMT constant sensitivity analysis).

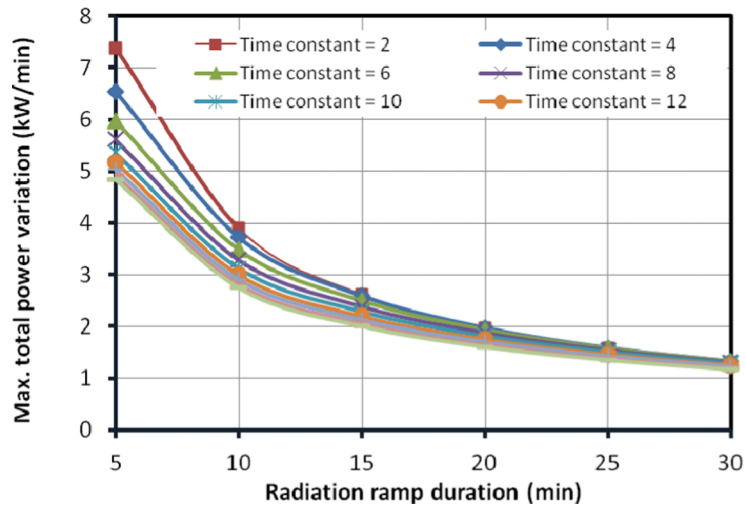

FIG. 11. Maximum total power variation (Radiation ramp duration and GMT model time constant sensitivity analysis).

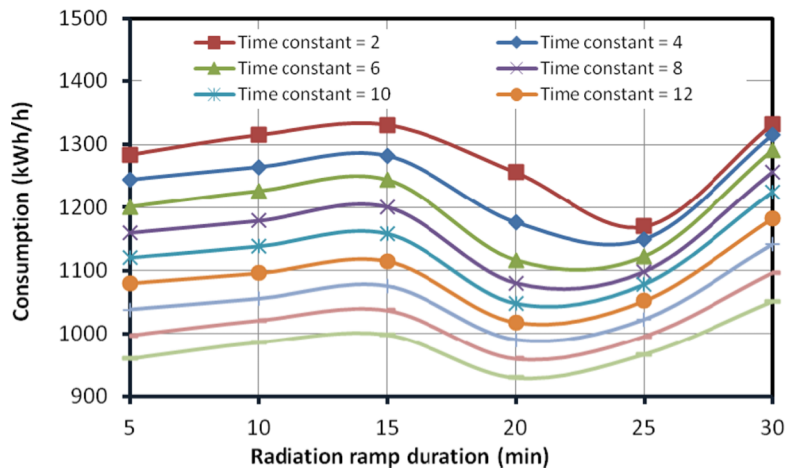

FIG. 12. GMT gas consumption (Radiation ramp duration and GMT model time constant sensitivity analysis).

In the case of natural gas consumption, the results show approximately the same variations for each GMT time constant (Fig. 12). In addition, gas consumption increases as the time constant of the turbine decreases (or increase GMT response time) for all cases studied. This increment follows an approximately linear law: a 40 kWh consumption increase per 2 minutes of reduction of the ramp.

VI. CONCLUSIONS

The new hybrid projects in emerging countries have led to increasing concern about the effects of their integration in the main grid, especially in remote areas. This paper studies these effects in a project designed to be installed in La Paz, Baja California Sur (Mexico). It presents and quantifies the variations in the performance of a hybrid power system composed of a GMT and a PV power system.

The different components of the system have been modelled using Matlab/Simulink software. They were successively tested with different solar radiation ramps that represent solar radiation variations, as well as with different time constants of the first order transfer function (GMT model) that represent GMT response time.

The results obtained in different radiation variation scenarios, maintaining a set GMT response time, reveal that for high radiation changes there was little difference in the power guarantee and the GMT gas consumption obtained; while these results varied greatly (obtaining the maximum and the minimum values) for smooth radiation changes. Additionally, it was found that the maximum total power variations reduce sharply as the radiation ramp duration increases.

Furthermore, it has been found that decreasing the GMT response times leads to higher power guarantees, quantifying this effect in most cases as a linear law (power guarantee increases 0.8% per 2 minutes of time constant reduction). Nevertheless, it implies that gas consumption and maximum total power variations also increase. Only in circumstances of a smooth radiation variation is there no appreciable difference in the maximum total power variation obtained for the different GMT response time.

ACKNOWLEDGEMENTS

This work has been supported by the Principality of Asturias through a Predoctoral Grant “Severo Ochoa”.

The authors would like to acknowledge the assistance of the Dra. Eunice Villicaña Ortiz in providing the information related with Mexico to carry out the work.

- ¹ J.P. Paredes-Sanchez, E. Villicaña-Ortíz, and J. Xiberta-Bernat, *Journal of Cleaner Production* **87**, 501 (2015).
- ² W.T. Chong, M.S. Naghavi, S.C. Poh, T.M.I. Mahlia, and K.C. Pan, *Appl. Energ.* **88**, 4067 (2011).
- ³ M.S. Ismail, M. Moghavvemi, and T.M.I. Mahlia, *Energ. Convers. and Manage.* **73**, 10 (2013).
- ⁴ J.L. Bernal-Agustín, R. Dufo-López, and D.M. Rivas-Ascaso, *Renew. Energ.* **31**, 2227 (2006).
- ⁵ Ph. Degobert, S. Kreuawan, and X. Guillaud, in *International Symposium on Power Electronics, Electrical Drives, Automation and Motion, Proceedings of the International Symposium on Power Electronics, Electrical Drives, Automation and Motion (SPEEDAM), Taormina, Italy, 23-26 May*, (IEEE, 2006), pp. 1223-27.
- ⁶ A. Nosrat and J.M. Pearce, *Appl. Energ.* **88**, 3270 (2011).
- ⁷ A. Arteconi, N.J. Hewitt, and F. Polonara, *Appl. Therm. Eng.* **51**, 155 (2013).
- ⁸ I. Stadler, *Utilities Policy* **16**, 90 (2008).
- ⁹ See California Energy Commission Document P500-03-089F (R. Lasseter, A. Akhil, C. Marnay, J. Stephens, J. Dagle, R. Guttromson, A. Sakis Meliopoulos, R. Yinger, J. Eto. CERTS Rep No.:LBNL-50829, 2002).
- ¹⁰ J.M. Pearce, *Energy* **34**, 1947 (2009).
- ¹¹ C. Brandoni and M. Renzi, in *ISES Europe Solar Conference Eurosun 2012, Proceedings of the Ninth International Conference of the European International Solar Energy Society ISES-EUROPE, Reijeka, Croatia, 18-20 September*, edited by B. Frankovic (2012).
- ¹² F. Basrawi, T. Yamada, and S. Obara, *Appl. Energ.* **121**, 174 (2014).
- ¹³ M.S.S. Ashhab, H. Kaylanib, and A. Abdallah, *Energ. Convers. Manage.* **65**, 777 (2013).
- ¹⁴ M.S. Ismail, M. Moghavvemi, and T.M.I. Mahlia, *Energ. Convers. Manage.* **75**, 271 (2013).
- ¹⁵ D. Dusabe, J.L. Munda, and A.A. Jimoh, in *AsiaPES 2008, Proceedings of the Second IASTED Asian Conference on Power and Energy Systems (AsiaPES), Langkawi, Malaysia, 2- 4 April*, edited by K.M. Nor (2008), pp. 327-333.
- ¹⁶ W. De Soto W, S.A. Klein, and W.A. Beckman, *Sol. Energy* **80**, 78 (2006).

- ¹⁷ H. Nikkhajoei and M.R. Iravani, in *Power Engineering Society Summer Meeting 2002, Proceedings of the Power Engineering Society Summer Meeting, Chicago, USA, 21-25 July* (IEEE, 2002), pp. 167-169.
- ¹⁸ MS. Ismail, M. Moghavvemi, and T.M.I. Mahlia, *Renew. Sust. Energ. Rev* **21**, 142 (2013).
- ¹⁹ R. Dufo-Lopez and J.L. Bernal-Agust, *Sol Energy* **79**, 33 (2005).
- ²⁰ A. Nafeh, in *ICREPO '10, Proceedings of the International Conference on Renewable Energies and Power Quality (ICREPO)*, Granada, Spain, 23-25 March (2010).
- ²¹ S. Sadeghi and M. Ameri, in *ISME 2012, Proceedings of the 20th Annual International Conference on Mechanical Engineering, Shiraz, Iran, 16-18 May* (2012).
- ²² J.L. Bernal-Agust and R. Dufo-Lopez, *Electr. Pow. Syst. Res* **79**, 170 (2009).
- ²³ Ph. Degobert, S. Kreuawanand, and X. Guillaud, in *ICREPO '06, Proceedings of the International Conference on Renewable Energies and Power Quality (ICREPO)*, Palma de Mallorca, Spain, 5-7 April (2006).
- ²⁴ HOMER Energy Model Software. National Renewable Energy Laboratory.
- ²⁵ Y. Cancino-Solórzano, E. Villicaña-Ortiz, A.J. Gutiérrez-Trashorras, and J. Xiberta-Bernat, *Renew. Sust. Energ. Rev.* **14**, 454 (2010).
- ²⁶ Y. Cancino-Solórzano, E. Villicaña-Ortiz, and J. Xiberta-Bernat, in *Congreso Iberico de Energía Solar2008, Libro de Actas del XIV Congreso Ibérico y IX Congreso Iberoamericano de Energía Solar, Vigo, Spain, 17-21 Junio*. pp. 1069-1071.
- ²⁷ E. Villicaña-Ortiz, Master thesis, Escuela de Ingeniería de Minas, Energía y Materiales, University of Oviedo, Spain, 2009.
- ²⁸ E. Villicaña Ortiz, Ph.D. thesis, Escuela de Ingeniería de Minas, Energía y Materiales. University of Oviedo, Spain, 2012.
- ²⁹ E. Villicaña Ortiz, J.A. Gutiérrez Trashorras, and J Xiberta Bernat, *Renew. Energ* **81**, 534 (2015).
- ³⁰ Y. Fernández Ribaya, E. Villicaña Ortiz, E. Álvarez Álvarez, and J. Xiberta Bernat, in *CIERM 2013, Proceedings of the 13th International Congress on Energy and Mineral Resources (CIERM), Cantabria, Spain, 3-4 October* (2013), pp. 16-23.
- ³¹ Y. Fernández Ribaya, Master thesis, Escuela de Ingeniería de Minas, Energía y Materiales. University of de Oviedo, Spain, 2012.
- ³² B.Y Liu and R.C. Jordan, *Sol. Energy* **4**, 1 (1960).
- ³³ J.A. Duffie and W.A. Beckman, *New York: John Wiley & Sons, Inc* (Hoboken, New Jersey, 1991).
- ³⁴ B. Todd and P.E. Henricks, Master Thesis, The Pennsylvania State University, 1997.